

# **Warner**

SPECIALTY PRODUCTS, INC.



Your **EXPERIENCED**  
Workplace **SOLUTIONS**  
**PROVIDER**

**Material Handling**  
**Ergonomic Solutions**  
**Storage Solutions**

1-800-750-3057

[www.warnerspecialty.com](http://www.warnerspecialty.com)

# Custom Work Platforms

**From design to fabrication we can customize any work platform to meet your needs.**

We have designed and built many different work platforms for all industries. These platforms provide a safe work environment reducing any risk of falling at various heights. They also provide employees the ability to work at an ergonomically correct height, reducing the risk of stress related injuries.

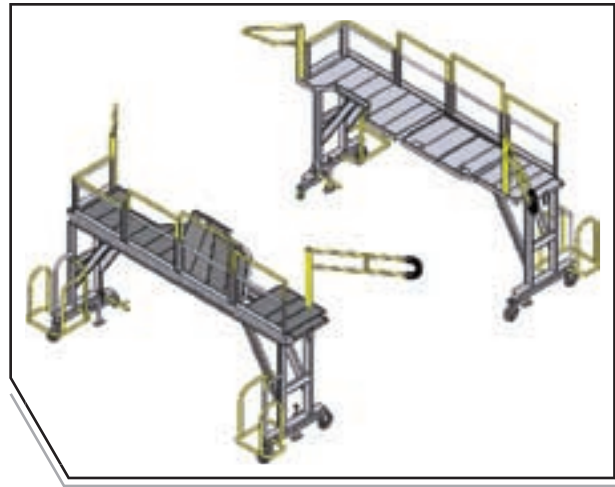

Here are a few of our designs for both Portable and Stationary Work Platforms.

120-Degree Access Platform

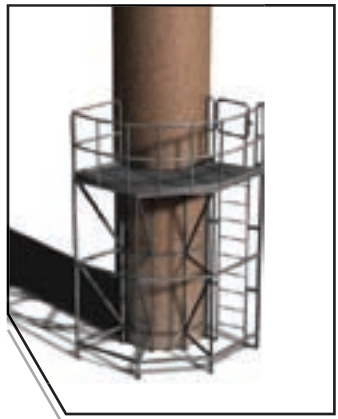

Octagonal Platform

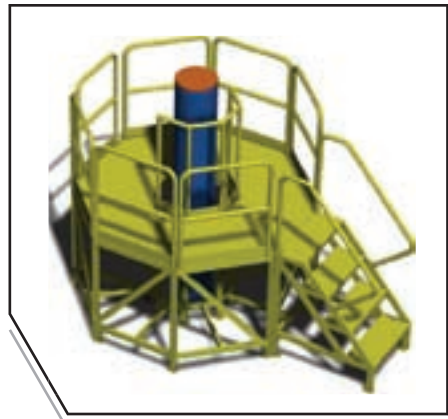

1-Person Ladder Platform



Dual-Height



5-Person Access Platform

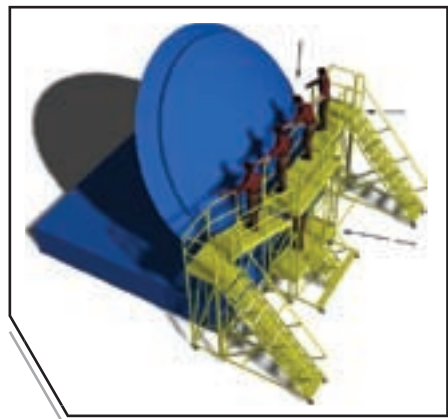

Tank Access Ladder



# Material Handling

## Custom Fabricated Equipment

We design custom material handling equipment for many different applications and settings. Some of these include custom designed workstation jibs, manipulators, bridge cranes, and custom lifting and tilting equipment.



This custom fabricated lift was designed and engineered to hold and lift a large fixture for the United States Space Program.

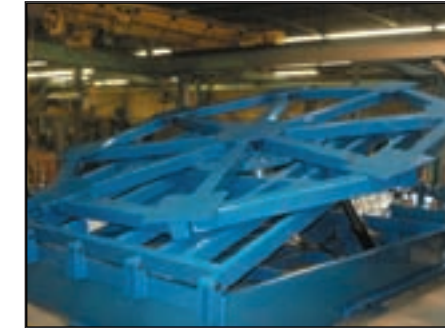

This custom manipulator allows our customer to work on transmission housings. The manipulator is completely automatic and allows transmission housings to be lifted up and down and rotated clockwise and counterclockwise.

# Fall Arrest Systems



Rigid fall arrest systems have many distinctive advantages over traditional wire rope systems.

The rigid track design has less free fall distance since the stretch of the wire rope does not have to be factored into the equation. The worker can also decelerate to a complete stop in a shorter distance, which lowers the impact energy on his body.

A rigid horizontal system reduces hazard on multiple personnel systems. On a wire rope system, movement of the wire rope from one person falling may cause other workers to fall. This hazard is eliminated by the use of SPANCO track which maintains its rigidity, thereby not affecting other workers on the same system. O.S.H.A. Standard No. 1910.66 App. C counsels caution when using wire rope for multiple personnel systems.

Need more headroom? Our rigid track design also saves up to three feet of headroom since there is no necessary allowance for sag.

# Modular Offices

Our modular offices and office systems include in-plant offices and wire enclosures. Indoor, outdoor, one story or two story are just a few styles of modular offices we offer. We offer on-site assembly.

## Modular Bullpen



Modular open air office space creates a clean and quiet work area. Installs quickly with little disturbance to the surrounding environment. Install is quick and clean!

## Modular Tool Crib



A secure tool/parts room can be created quickly & efficiently. It can be engineered in 2,3, or 4 wall configurations.

## 2-Story In-Plant Office



2 story modular offices maximize floor space. It can be installed in a fraction of the time it takes for conventional construction, with the tax advantages of capital equipment!

# Wire Partitions/Lockers

## Wire Partitions

Secure your property with a Wire Mesh Partition system. Made to fit, our modular wire mesh partitions deliver 24-hour security while its all-steel construction resists wear and requires no maintenance.

Various styles and types are available. Fits various applications. Wire fencing can be customized to match the color of your shop.



## Condo Lockers

Condo Lockers are the locker of choice with developers, contractors and condominium owners.

Made to your specifications, our industrial lockers have few components, are easy to assemble and allow you to turn an unused area into a practical and secure storage space effectively and economically.

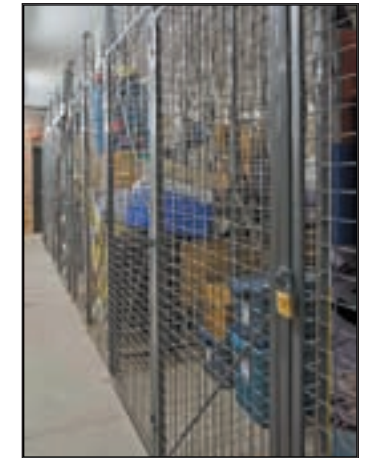

## Shelters



## Guardhouses



# Mezzanines

**Transform unused overhead space into space that works.** Free-standing mezzanines are designed to satisfy your need for additional space by maximizing the use of existing areas. They offer you virtually unlimited options for modifying your present interior spatial configuration. As a result, you can increase your usable floor space without the expense of modifying the building layout or moving into a larger facility.



# Workstations

Various types of manually and electrically adjustable workstations, as well as fixed height, for when a task or operator demand a set height.

## Industrial



## Laboratory

We can provide workstations to match your precise, clean, and professional laboratory. Multiple storage options organize equipment and supplies. These workstations help you focus on productive research and testing.



## Packaging

These workstations will help you get your product packed up and out the door. Fulfillment centers, kitting area, shipping and receiving departments, or general packing will benefit from these workstations.



# Modular Cabinets/Shelving

## Portable & Stationary Cabinets

Modular drawer cabinets are available in various widths and heights. You can configure a cabinet to your requirements or select from a list of standards.

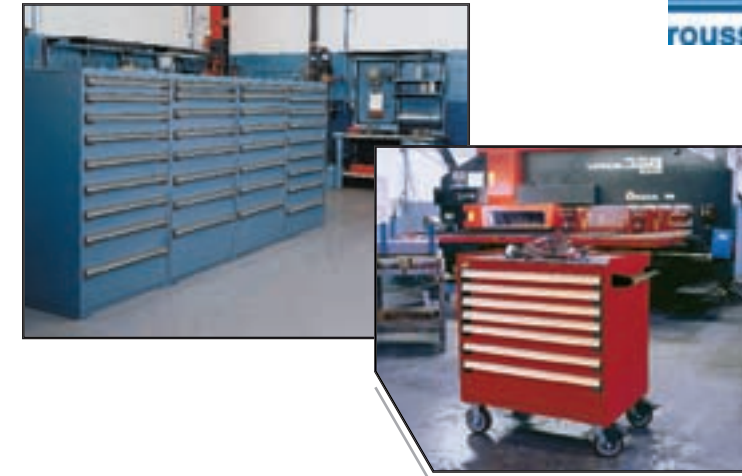

## Spider Shelving System

This innovative and versatile storage system is designed to accommodate various types of shelving, drawers and mini racking on a single post style.



# Ergonomic Chairs

## Office Environment



## Shop Environment



## Overhead Task



## Cleanroom & ESD

ESD models for locations where electro-static discharge is a concern. Cleanroom models are available for various cleanroom environments.



## Stools & Sit-Stands

Ideal for jobs in which you're not seated for long periods of time.



## Polyurethane Chairs

Our self-skinning polyurethane is an ideal material for laboratories or multi-shift environments where hygiene is a concern.



# Foam Cutouts & Custom Crating

Custom foam cut-outs for cases, drawers, and toolboxes. Custom crating for storing or transporting valuable items.

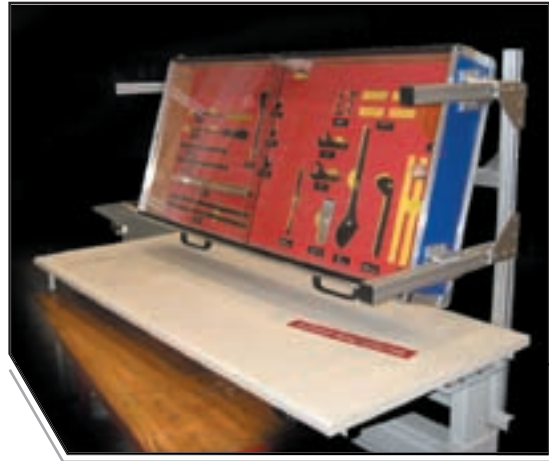

# Metro® Racks

Wire shelving & portable wire racks. Portable units are available with wire or solid shelves. Available in various materials, stainless steel, galvanized, chrome or zinc plated. Shelves are easy to adjust.



Super-adjustable shelves are very easy to adjust.

# Custom Carts

Custom fabrications are designed and engineered for applications where standard products fall short of your needs.



# Tilt Tables

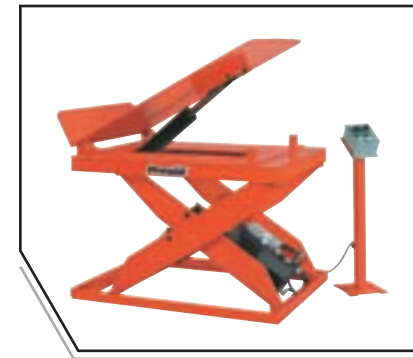

# Scissor Lift Tables



# Custom Lift Tables

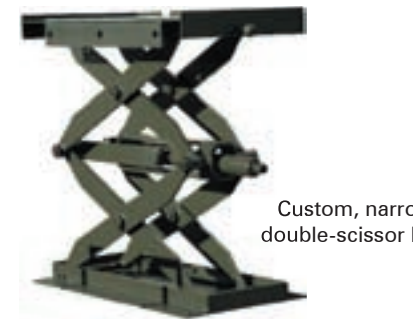

Custom, narrow double-scissor lift

# Custom Lifts with Rotary Tops



Lift with expandable arms



Powered lift/tilt/spin

# The Mule

## The Portable, All-in-One Stacker, Transporter & Work Positioner

It's also a portable work bench. This ergonomic lift is ideal for moving boxes and rolls of packaging material, supplies, finished goods, etc. The Mule™ is narrow so it moves easily through spaces other lifts can't negotiate.

- Versatile
- Hand Operated Brake
- Agile
- Electrically Powered
- Screw-Driven Lift
- Safety Sensor
- Adjustable Work Clamps
- Built-In Vise
- Platform Flexibility
- Endless Applications
- Quick Charging



# Presto PowerStak™

## High-Performance, Fully-Powered Stacker...

providing instant flexibility and versatility. It's sleek, stylish design, low overall weight, and quiet operation allow the PowerStak to fit nicely into a wide variety of work environments including:

- Warehouses
- Loading Docks
- Light Assembly
- Work Cells
- Retail Sales Floors



Four PowerStak models are available to satisfy just about any requirement including servicing racks up to 10 feet high.

## Bins & Racks

Hanging systems accommodate bins to create stationary and mobile storage centers.

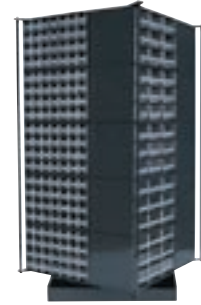

Storage-Go-Around

Color code inventory with 13 sizes and 3 colors



Tip-Out Bins

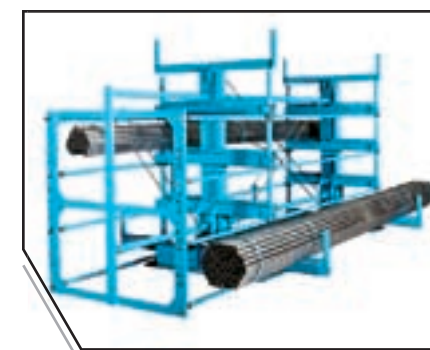

## Attached Lid Containers

Reusable shipping, distribution, and storage containers. Nest when empty to save space.



## Molded Fiberglass Trays, Pans, & Containers

- Reinforced Steel Edges
- Mobile Dolly Options
- Lids
- Dividers
- Custom Sizes Available



## Milplast Corrugated Plastic Containers

- Infinite variety of structural designs.
- Cost-effective for custom designs and short runs
- Collapsible
- Durable
- Lightweight



## Matting

**Comfort**  
Will withstand the harshest of industrial environments to provide a long-term solution for your anti-fatigue needs. Available in closed and open patterns.



**Ergo**  
These light and smaller, rectangular mats make them ideal for use at workstations, locker rooms and shower facilities.



**Excel**  
With excellent drainage capabilities, these mats are designed for wet environments.

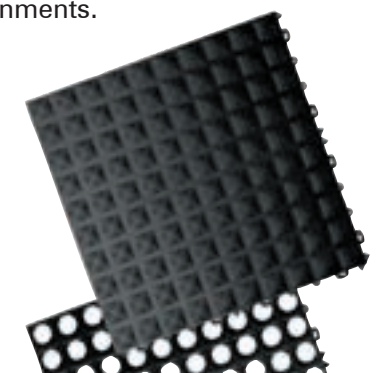

# Warner

SPECIALTY PRODUCTS, INC.

## Installation Services



Warner has been performing high quality installations for over 20 years. Our experience allows us to perform clean, safe, and on time installations in accordance with OSHA best practices.

- In Plant Offices
- Fall Arrest Systems
- Mezzanines
- Wire Partitioning
  - High Wall
  - Tool Cage
- Lockers
  - Personnel
  - Condo
- Workstations
- Racking
  - Bulk
  - Pallet
- Conveyors
- Cranes
  - Bridge
  - Jib
  - Gantry
- VRC's

Warner Specialty  
Products, Inc.

1484 Highland Ave.  
P.O. Box 69  
Cheshire, CT 06410

Toll-Free: 1-800-750-3057  
Phone: (203) 272-3500  
Fax: (203) 272-2329

[www.warnerspecialty.com](http://www.warnerspecialty.com)

## Vendors

